

SCHOTT
glass made of ideas

SCHOTT TopPac®

Polymer Prefillable Syringes



SCHOTT is an international technology group with more than 125 years of experience in the areas of specialty glasses and materials and advanced technologies. With our high-quality products and intelligent solutions, we contribute to our customers' success and make SCHOTT part of everyone's life.

SCHOTT Pharmaceutical Systems is one of the world's leading suppliers of glass tubing, primary packaging and specialized analytical lab services for the pharmaceutical industry. We provide our customers quality solutions while meeting their highest demands with our expertise and broad product portfolio; including ampoules, cartridges, vials and syringes made of glass and COC polymer. Our state-of-the-art production facilities and our products comply with the highest international quality standards for pharmaceutical needs.

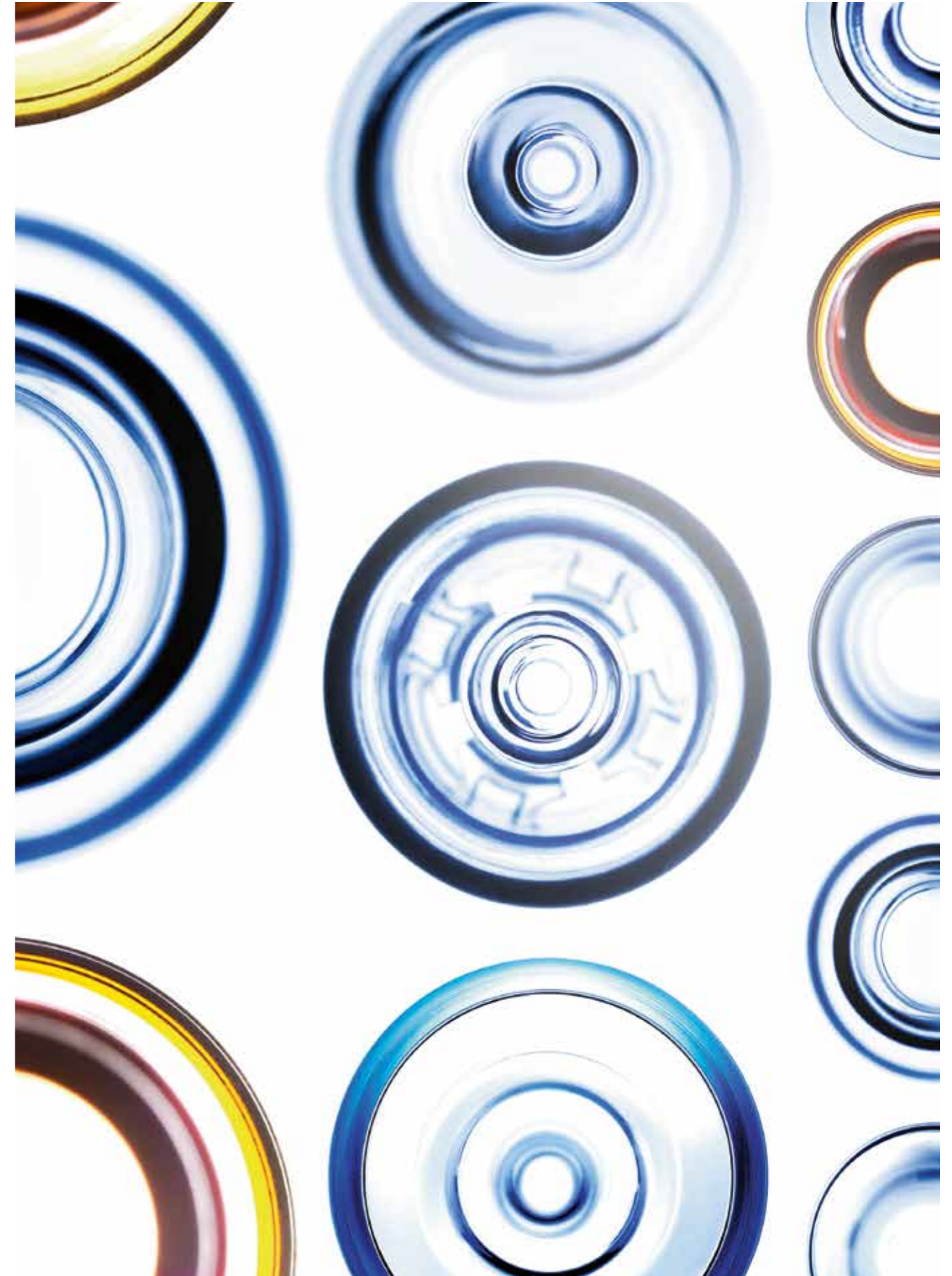

Perfect Integration

Perfect Integration is how we believe we can make a difference to your business. With SCHOTT, you not only get customised products and solutions, but a partner you can trust. A forward thinking team of professionals from R&D to sales, all working together closely with

you, strive for converting decades of research and investment into sustainable and successful pharmaceutical products. In short: Perfect Integration is our belief, our way forward, to empower your success.



Contents

- 8–9 COC Excellent Material for Pharmaceutical Packaging
- 10–15 Broad Product Portfolio
- 16–17 Benefits of SCHOTT TopPac® – Expertise Perfectly Integrated in Your Product
- 18–19 Our Manufacturing Process – Fully Integrated Clean Room Production
- 20–21 Compliance with International Norms
- 22–23 SCHOTT – Your Partner throughout the Drug Life Cycle





COC Excellent Material for Pharmaceutical Packaging

The right chemistry is with SCHOTT: we continuously develop new solutions and process improvements in close cooperation with our global customers. Our 15 years of polymer and 125 years of glass expertise make us an ideal partner for innovative solutions that are shaping the future of the pharmaceutical industry.

TOPAS® 6013 – our raw material

Drug shelf life depends on material purity, inertness, and barrier properties of the storage container. Our basic material for SCHOTT TopPac® syringes, Cyclic Olefin Copolymer (COC) – TOPAS® 6013 – is an advanced polymer which is manufactured in accordance with EP, JP, and USP class VI (DMF 12132). It is based on metallocene technology and used as the standard raw material for all available TopPac syringe formats.

The benefits of TOPAS® are:

- Transparent (glass-like appearance)
- No ion or heavy metal release due to biologically inert COC material
- Non-polar syringe contact surface
- Excellent moisture barrier properties

Our production process ensures that SCHOTT TopPac® syringes are made of 100% uniform material. TopPac syringes offer optimal barrier properties for water vapor and oxygen permeability as well as light protection for the long-term storage of a broad range of parenteral products such as protein-based drugs or products with extreme pH values.

Physical properties of COC polymer

	Unit	Test method	TOPAS® 6013
Heat deflection temperature HDT/B at 0.45 MPa	°C	ISO 75 part 1 and 2	130
Water vapor permeability (23°C; 85% r.h.)	g x mm / m ² x d	DIN 53122	0.035
Water absorption (water immersion at 23°C)	%	ISO 62	<0.01
Density	g/cm ³	ISO 1183	1.02
Tensile strength	N/mm ²	ISO 527 part 1 and 2	66
Impact strength (Charpy)	kJ/m ²	ISO 179/1eU	15
Light transmission	%	ASTM D 1003	92

Water vapor permeability

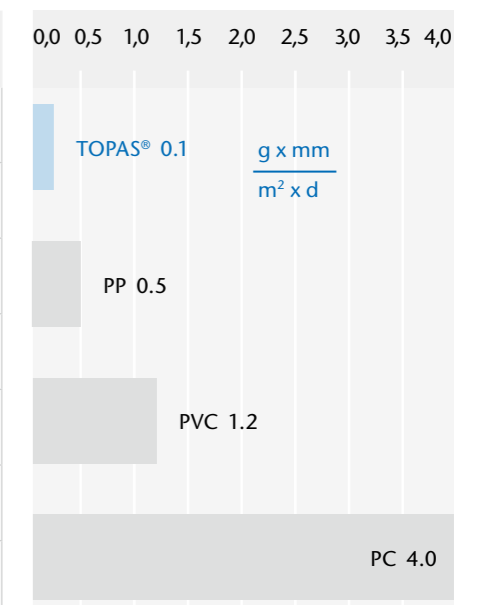

Comparison of different polymers measured at 40°C/90% r.h.

Broad Product Portfolio Designed for a Variety of Applications

SCHOTT TopPac® prefillable syringes (PFS) are delivered in nest and tub configuration and are ready for filling process. Terminal sterilization (autoclaving) after filling is possible. SCHOTT TopPac® syringes are suitable for long-term storage as well as the administration of injectable

Hyaluronic acid



Infusion therapy



drugs for a variety of therapeutic areas within the hospital care environment, clinical setting, or home care such as highly viscous drugs like hyaluronic acid, infusion therapy, biotech, or emergency drugs.

Emergency drugs



Diluents



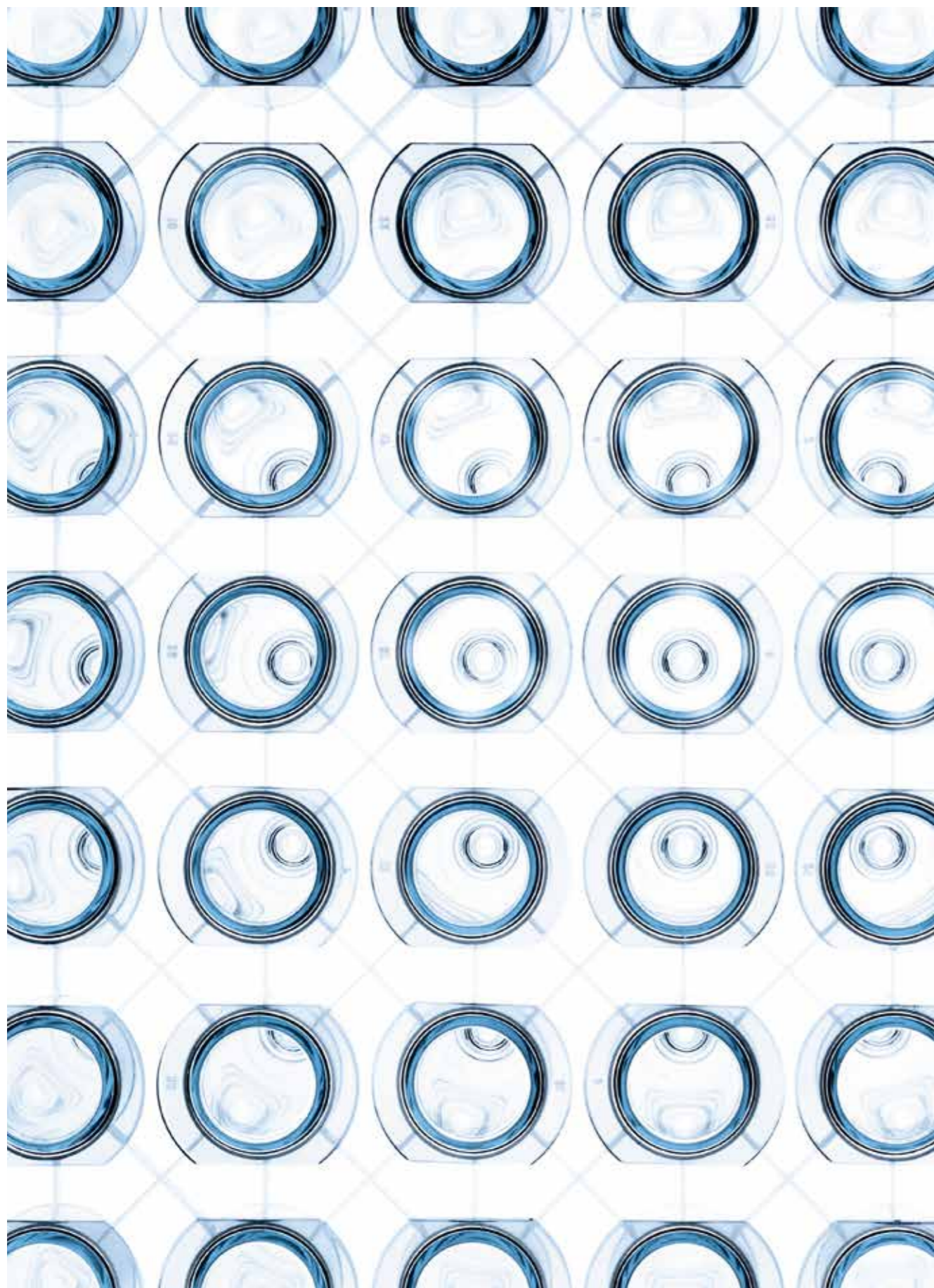

SCHOTT TopPac® Syringe System Ready-to-Use

From small (1–5 ml) to large volume (10, 20, and 50 ml) syringes:
Our injection molding process in combination with our COC raw material provides design flexibility to create customized solutions for specific drug applications.

Syringe components and packaging

SCHOTT TopPac® syringes are delivered ready for the filling process. They are assembled with a tip cap and packed in a nest which is placed into a tub. The tub is covered by a Tyvek® inlay, placed in the tub and sealed with a Tyvek® seal. After being packed in double polyethylene bags, the tubs are sterilized.

SCHOTT TopPac® syringes are available as a complete system including components such as plungers and plunger rods according to the customer's requirements. This allows fast and efficient integration in existing filling lines.

All syringe barrels are made of COC material, with integrated Luer Lock and are assembled with closure systems, e.g. the FM257/2 rubber tip cap from Dätwyler.





Small volume syringes
Formats: 1–5 ml



Large volume syringes
Formats: 10, 20, and 50 ml

A Comprehensive Portfolio: Broad Drug Delivery Solutions

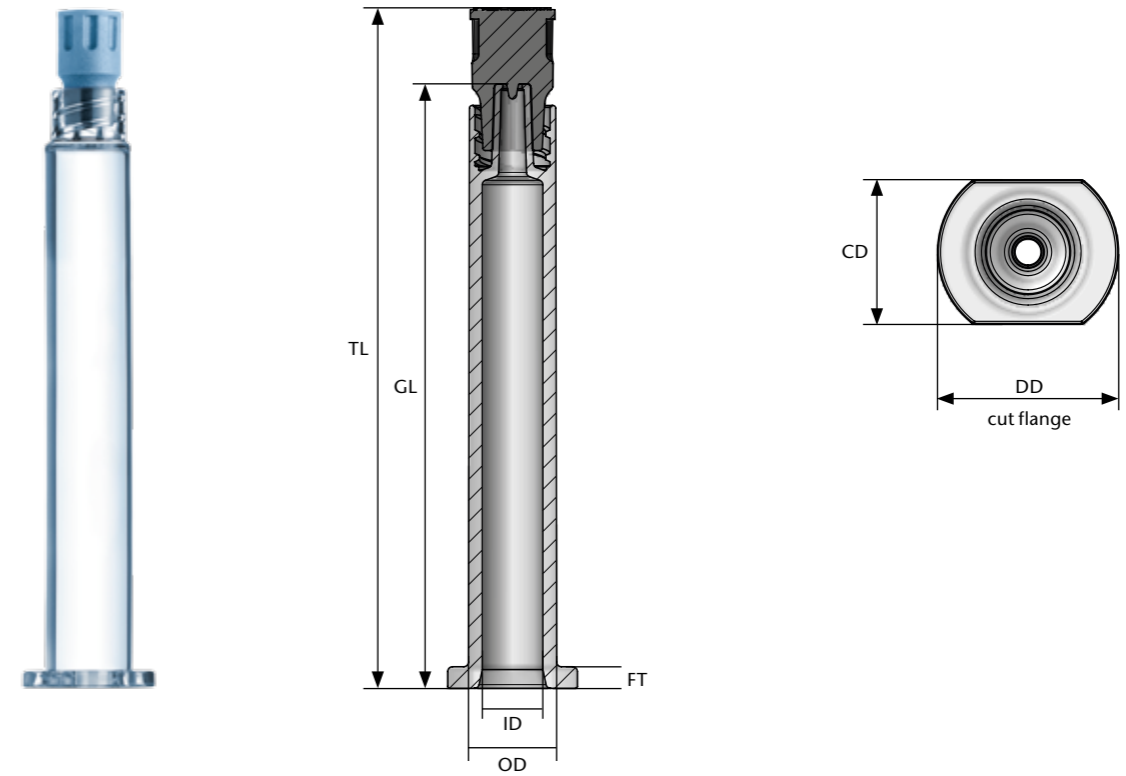

Format in mm	Total Length (TL)	COC Barrel (GL)	Inside Diameter (ID)	Outside Diameter (OD)	Flange Thickness (FT)	Flange (DD)	Flange (CD)	Pieces per tub
1.0 ml lg	72.6	64.5	Ø 6.5	Ø 9.4	2.3	Ø 13.8	Ø 11.0	100
1.0 ml	54.0	45.9	Ø 8.75	Ø 11.4	2.3	Ø 17.75	Ø 14.7	100
2.25 ml	72.5	64.4	Ø 8.75	Ø 11.4	2.3	Ø 17.75	Ø 14.7	100
3.0 ml	90.5	82.4	Ø 8.75	Ø 11.6	2.3	Ø 17.75	Ø 14.7	100
5.0 ml	85.0	76.9	Ø 12.2	Ø 15.0	2.3	Ø 23.0	Ø 19.5	64
10.0 ml	105.8	97.7	Ø 14.7	Ø 18.0	2.3	Ø 27.0	Ø 21.5	42
20.0 ml	128.3	120.2	Ø 18.2	Ø 21.6	2.3	Ø 26.0	Ø 38.0	30
50.0 ml	136.9	128.8	Ø 27.9	Ø 31.5	3.0	Ø 36.0	Ø 50.0	20

- All barrels made with TOPAS® 6013
- Standard tip cap is Dätwyler FM 257/2
- Gamma sterilized

For more details on the SCHOTT TopPac® portfolio and customization options please contact your local SCHOTT representative.

Benefits of SCHOTT TopPac® – Expertise Perfectly Integrated in Your Product

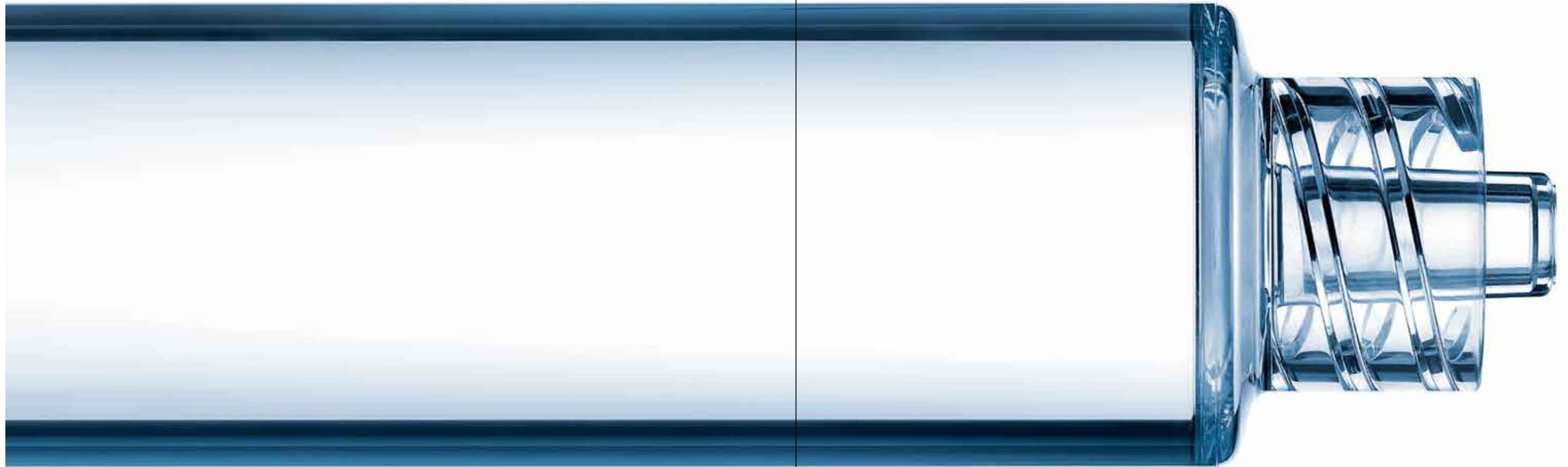

Break-resistant and lightweight

Due to high break-resistance and a lightweight, polymer syringes are suitable for highly viscous products and emergency situations.

Glass-like transparency

Transparent COC raw material for easy visual inspection on the filling lines.

Integrated Luer Lock

Minimization of leakage, Luer Lock rotation, needle ejection and disconnection of Luer Lock adapter during injection.

Design flexibility

Broad range of sizes (1–50 ml), with integrated Luer Lock and cut flange with ergonomic design.

Consistent gliding force

Precise and smooth drug application through distinctive barrel wall thickness and crosslinked siliconization.

Ready for filling

Easily integrated into existing filling lines with minor modifications.

Compatible with needleless IV connectors

Compatible with popular Needleless Luer Access Devices (NLADs) to avoid malfunction, breakage, and clogging.

Optimized for syringe pumps

Safe syringe pump recognition due to specific syringe barrel outer diameter.

Clean with low particle level

Fully integrated clean room production results in syringes with low particles and low contamination.

Our Manufacturing Process – Fully Integrated Clean Room Production

SCHOTT TopPac® syringes are manufactured on state-of-the-art production lines with highly stable and validated processes. Permanent process optimization by Six Sigma principles and continuous training of employees help to maintain the highest quality levels.

Clean room ISO 6

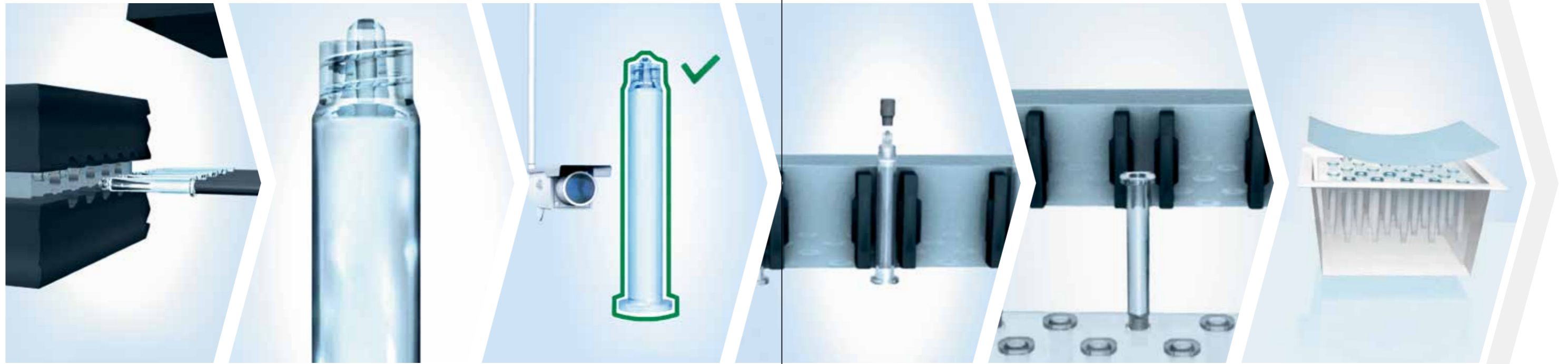

Injection molding

The sophisticated injection molding process enables tighter dimensional tolerances on the syringe barrel and higher process stability for consistent quality.

Siliconization

After the injection molding and cooling phase, SCHOTT TopPac® syringes are siliconized with a reactive silicone mixture, which is followed by a curing process resulting in the cross linking of the silicone to the inside of the syringe barrel. This process ensures an even distribution of silicone in the syringe barrel with an extremely low level of free silicone.

Camera inspection and closure assembly

After siliconization the syringes are camera inspected for cosmetic defects and are fitted with tip caps. The tip cap design and the setting process are optimized to ensure closure tightness.

Nesting

To protect the syringes against contamination and damage, they are placed in nests and transparent tubs, which can be easily processed in all common filling lines.

Tub sealing and packaging

A protective Tyvek® inlay is placed in the tub followed by a Tyvek® seal to build a barrier against microbial contamination. The sealed tubs are covered with a polyethylene double bag. They are then visually inspected, packed into boxes and pallets, and sent for sterilization.

The production of SCHOTT TopPac® syringes is a continuous, fully integrated process that takes place in an ISO class 6 clean room and starts with the automated transfer of raw material from the silos directly into the injection molding machines.

Compliance with International Norms: Excellent Quality for Superior Performance

The quality of our SCHOTT TopPac® syringes starts with:

- Fully automated production lines
- cGMP and continuous training of personnel according to strict production process guidelines
- Reliable quality systems and rigid quality controls for consistent high-quality
- State-of-the-art camera systems for dimensional and cosmetic control
- In-process control (IPC) for compliance with specifications of barrel dimensions, cosmetic quality, and functionality

Quality management system

All SCHOTT TopPac® syringes are manufactured according to ISO 9001, ISO 15378, and ISO 13485. Additionally, the production process is optimized with a continuous improvement program based on Six Sigma principles.

Regulatory compliance

Due to strict quality control and excellent process capability, SCHOTT TopPac® syringes comply with the international norms like EP, USP, and JP. SCHOTT TopPac® syringes are filed with the FDA under DMF 18416 and with Health Canada under 09-058.



SCHOTT – Your Partner throughout the Drug Life Cycle

Our dedicated cross-functional team offers advanced customer consulting services through all drug life-cycle stages in order to find optimal solutions to meet your individual needs.

Drug development



Extensive support for packaging selection:

- Customer value chain evaluation
- Technical product specifications (TPS)
- Samples from stock

Your partnership with SCHOTT starts with a quick evaluation of your value chain to understand the requirements of the drug and primary packaging. SCHOTT will provide you with all the relevant information on our syringe systems along with samples from stock, standard technical product specification (TPS), and an extractable report, which can help you define the leachables study. In case of special design requirements, we will support you in defining the syringe specifications and estimating the development efforts with regard to project cost and timeline.

Regulatory support

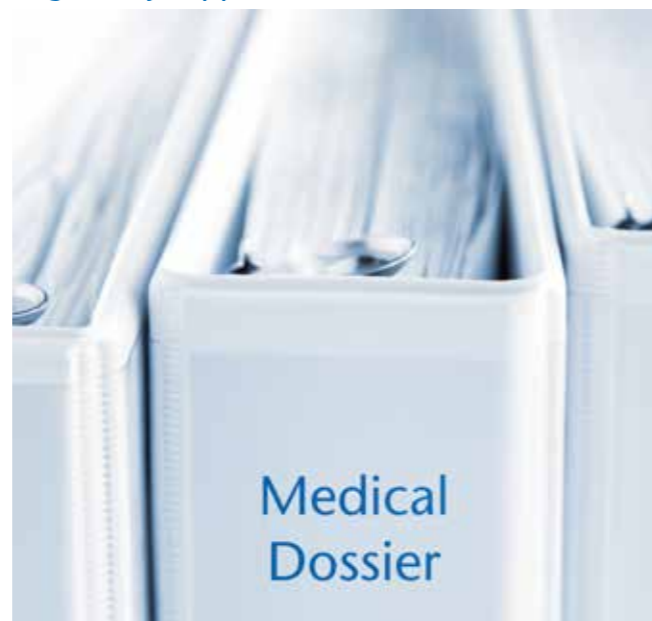

Regulatory filing facilitated by:

- Cooperative audits
- Comprehensive technical dossier
- LOA for DMF

To support your registration activities, an established TPS, technical dossier, and the Letter Of Authorization (LOA) for the Drug Master File (DMF) will be provided.

Commercial manufacturing



Enabling smooth operation and supply chain:

- Capacity and supply security
- Short lead times
- Competent complaint management

In the commercial phase we ensure supply security of the products through flexible and efficient supply chain management. Together, we can minimize total cost of ownership. If any issues related to quality or technical improvements should occur, our SCHOTT team including Quality Management, Process Engineering, and R&D provides a fast and reliable root cause analysis and problem solving.

Life-cycle management



Added value through innovative solutions:

- Continuous technology development
- Constant product improvement
- Product innovation

Primary packaging is seen as a differentiating factor in a competitive market place. Life-cycle management of existing products may involve a change of primary packaging. In such cases, a dedicated cross-functional project team is established to assess feasibility, development costs, and timeline.

Pharmaceutical Systems

SCHOTT AG

Hattenbergstrasse 10

55122 Mainz

Germany

Phone: +49 (0)6131/66-1589

Fax: +49 (0)6131/66-1916

pharmaceutical_packaging@schott.com

www.schott.com/pharmaceutical_systems